

Sellacopter[™]
List it. Sell it. Done.



1995 Robinson R22 Beta

Serial Number 2526

1995 Robinson R22 Beta

Serial Number 2526

Aircraft Highlights

- Well Maintained
- Clean Interior/Exterior
- Significant time remaining in M/R and T/R Blades

Airframe

Registration Number N951KC
Airframe Total Time 4,180 Hours
Annual Performed April 2021

Exterior

- White and Red
- 8/10

Engine

Engine Type Lycoming O-320-B2C
Serial Number L-13379-39A
Engine TSOH 2,167

Interior

- Grey Cloth W/ Plastic Floor Mats
- 9/10

Robinson R44

Raven II

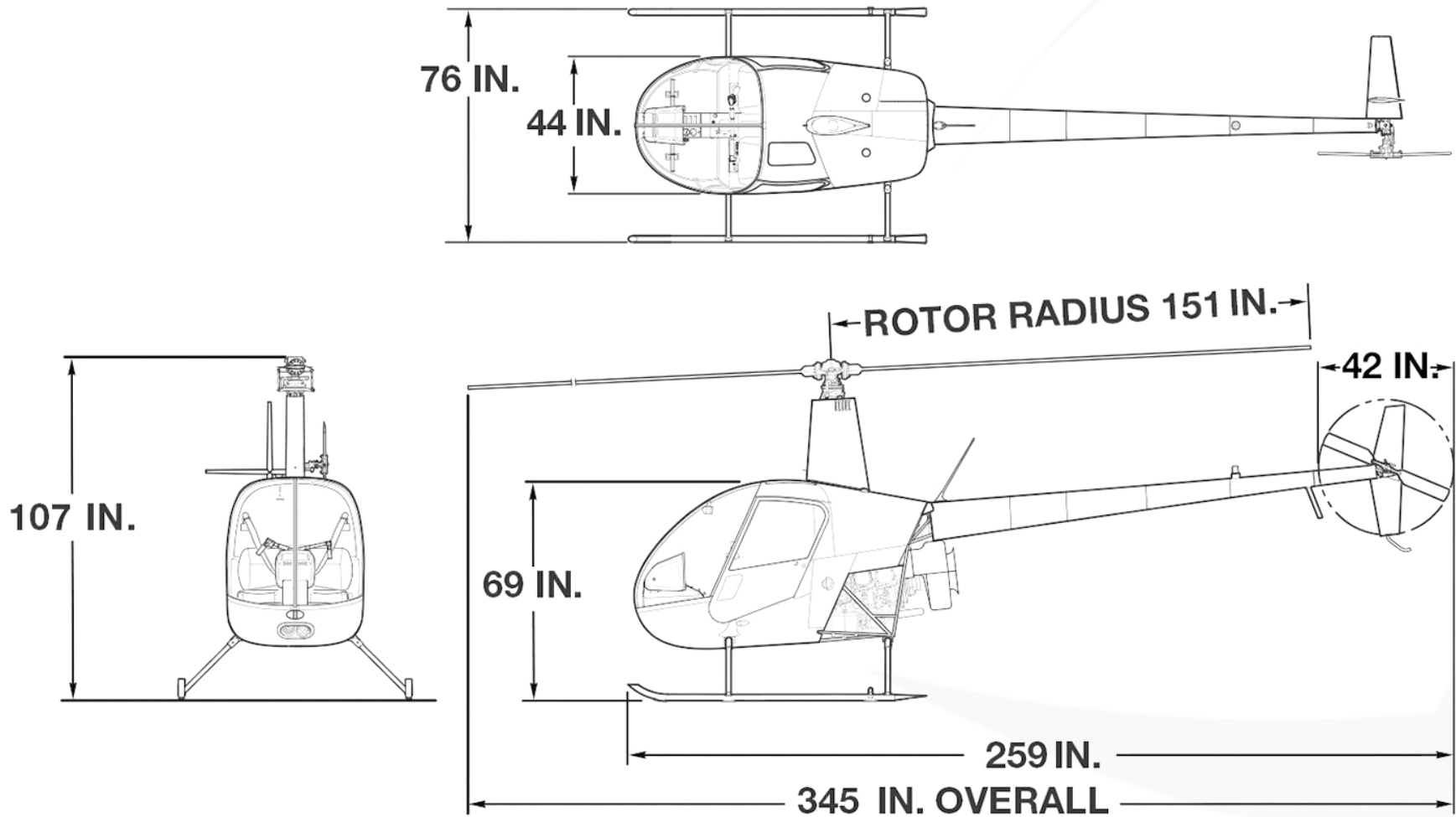



Avionics / Instruments

Bendix/King
KY197A
Comm

KT76
Transponder



COMPONENT	Current Time	TBO
AIRFRAME	1,480.4	34
ENGINE	11,151.3	32.9
MR BLADES	524	1,676 / 8yrs
TR BLADES	972	1,228 / 3yrs



Contact us



Zack Robinson

 512-886-8220

 Zack.R@sellacopter.com

Halsey Schider

 512-886-8300

 Halsey.S@sellacopter.com

Office

 1-855-SELLACOPTER (735-5226)

 Sales@sellacopter.com

 Sellacopter.com